

Note: Part numbers and standards' values may change. Consult LECO for the latest information.

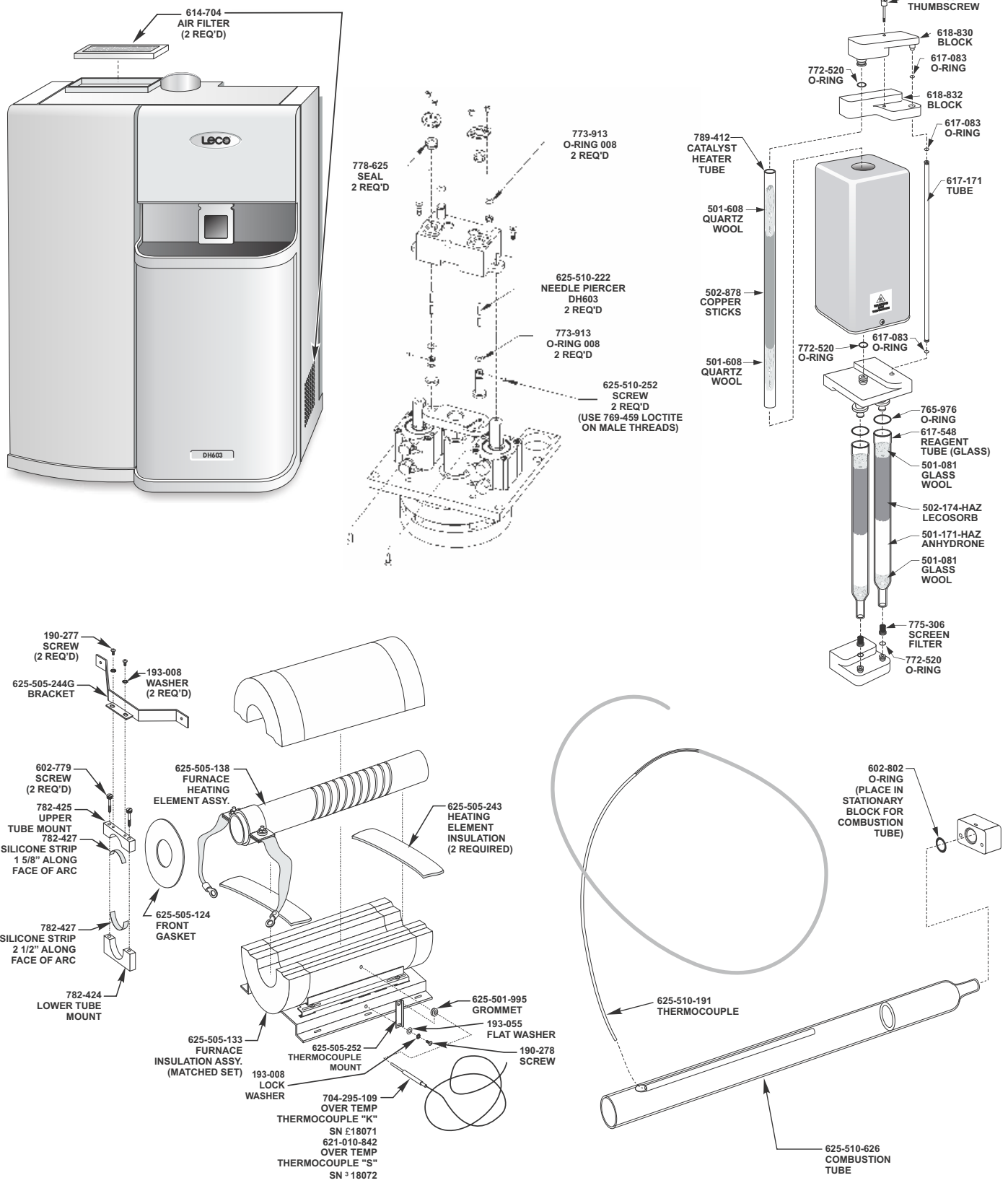

See reverse side for contact information

OPERATING SUPPLIES

625-510-626 Combustion Tube

CATALYSTS AND REAGENTS

501-171-HAZ Anhydron 454 g (1 lb.) bottle (10-16 mesh)
 502-878 Copper Sticks (100 g)
 501-081 Glass Wool 454 g (1 lb.) bottle
 502-174-HAZ Lecosorb 500 g bottle, (20–30 mesh)
 502-176-HAZ Lecosorb 500 g bottle, (8–20 mesh)
 501-608 Quartz Wool 200 g bottle
 501-241 Vacuum Grease 3.5 oz.

REAGENT TUBES

617-548 Glass Reagent Tube, requires one 772-520 and two 765-976 O-rings
 789-412 Quartz Catalyst Heater Tube, requires two 772-520 O-rings
 625-510-129 Glass Reagent Tube, requires two 772-520 O-rings

EVACUATED STEEL SAMPLER WITH INNER STEEL PIN

903-9A3-174 3-foot Cardboard, 6-inch Non-Splash Sleeve without Anti-Skull Coat
 903-9A3-184 3-foot Cardboard, 6-inch Non-Splash Sleeve with Anti-Skull Coat
 903-9A3-124 3-foot Cardboard, 12-inch Non-Splash Sleeve without Anti-Skull Coat
 903-9A3-194 3-foot Cardboard, 12-inch Non-Splash Sleeve with Anti-Skull Coat
 903-9A1-184 1-foot Cardboard, 6-inch Non-Splash Sleeve without Anti-Skull Coat

EVACUATED STEEL SAMPLER WITH QUARTZ LINING

903-9B3-174 3-foot Cardboard, 6-inch Non-Splash Sleeve without Anti-Skull Coat
 903-9B3-184 3-foot Cardboard, 6-inch Non-Splash Sleeve with Anti-Skull Coat
 903-9B3-124 3-foot Cardboard, 12-inch Non-Splash Sleeve without Anti-Skull Coat
 903-9B3-194 3-foot Cardboard, 12-inch Non-Splash Sleeve with Anti-Skull Coat

EVACUATED PIN TUBES FOR RAPID SAMPLING OF MOLTEN METALS

| Part No. | Description | Dimensions | Qty. |
|-------------|--------------------|--|----------|
| 511-036-150 | Standard Pin Tube | 4 mm ±0.2 mm (0.159" ±0.009") ID x ~146 mm (5.75") L | 1500/pkg |
| 511-039-150 | Standard Pin Tube | 3.5 mm ±0.2 mm (0.39" ±0.009") ID x ~146 mm (5.75") L | 1500/pkg |
| 511-037-150 | Precision Pin Tube | 4 mm ±0.025 mm (0.159" ±0.001") ID x ~146 mm (5.75") L | 1500/pkg |
| 511-244 | High Vacuum Tube | 6 mm (0.236") ID x 125 mm (4.92") L | 100/pkg |

OPERATION ACCESSORIES

619-995 Bar Code Reader, USB
 618-241 Nut Removal Tool
 511-038 Pin Tube Holder
 782-508 Quartz Wool Puller/Packing Tool Assembly
 625-505-137 Quartz Boat Tweezer
 625-510-146 Sample Puller Assembly
 761-822 Tool Kit
 760-138 Tweezer
 625-510-628 Type "K" to Type "S" Over Temp Thermocouple Conversion Kit

NOTE: Part numbers and standards' values may change. Consult LECO for latest information.

Please Note: Quartz Tubes are typically utilized for higher temperature applications (i.e. catalyst tubes). Glass reagent/filter tubes are designed for lower temperature applications. Glass tubes should not be used in place of quartz tubes.